

The High Quality Route to clean water.



Water Quality values

ProCrop[®] IRRIGATION WATER TECHNOLOGY FROM TREATMENT CFS.
THE HIGH QUALITY ROUTE TO CLEAN WATER



The Quality Company – Worldwide



An Undoubtedly Quality

Water is undoubtedly the life blood of growing crops and increasingly supplementary amounts in the form of irrigation are both necessary and targeted at specific stages of crop growth. However irrigation water may contain physical, chemical and biological contamination which can adversely affect the equipment used to deliver the water, the yield and quality of the crop. The quality of your crops is determined by irrigation water quality, raw water may hold high concentrations of salt, hardness and elevated Ph and lack the essential elements needed by your Plant.

For flow rates between 20 liters and 100 m³ per hour TREATMENT[®] is your expert partner where ecological and economical water purification is concerned. The standardized system components allow individually tailored solutions at attractive prices.

The name TREATMENT[®] stands for reliable pure water technology and satisfied customers. In all areas where pure water is required TREATMENT[®] provides clear solutions. Our company concept ensure effective problem solutions ,reliable operation of our equipment and rapid service on site.

High quality route

legislation and environmental issues pertaining especially to pollution and salinity of water resources are leading to the introduction of restrictive measures regarding the disposal of plant grow solutions.

New regulations are stimulating growers to invest in advanced water technology systems.

Benefits for the customer

- attractive prices
- High quality crops
- Quality & Project Plan / Validation Plan
- Validation strategy
- Validation protocols
- Review of certificates, technical documentation
- Change control
- Service contract with full documentation
- low capital Investment

Service after system handover

The TREATMENT[®] Customer Services include fault-diagnosis Systems up to and including remote assistance and a 24-hour Hotline.

Fields of Activity

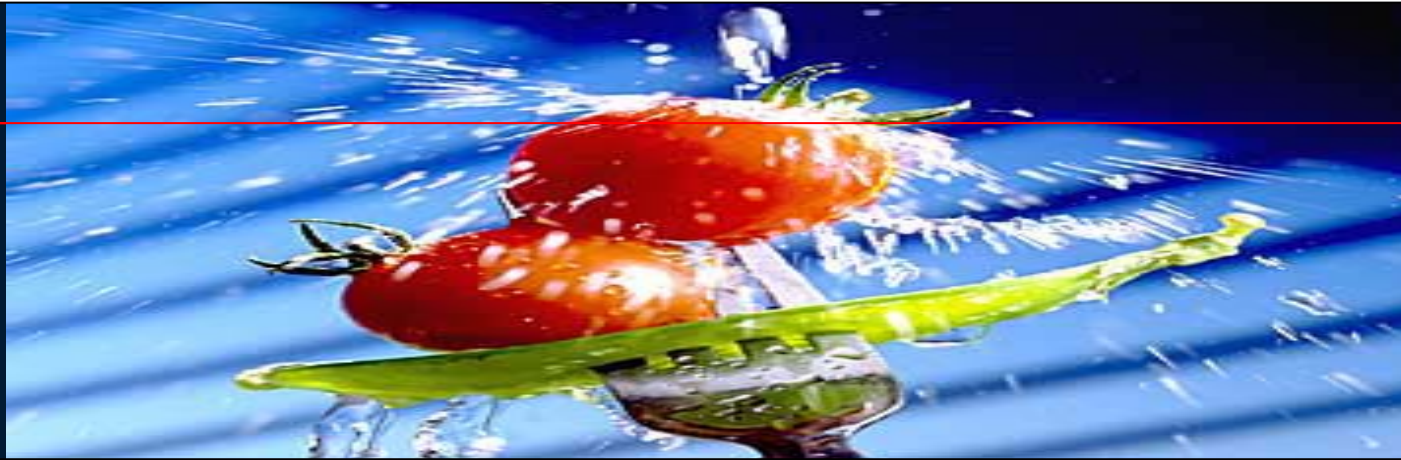

ProFilter® Water recycling systems4

ProFlow® Transfer Pumps16

ProKit® Water quality check.19

ProFilter[®] ProLoop[®] Water Recycling Systems Pathogen Prevention

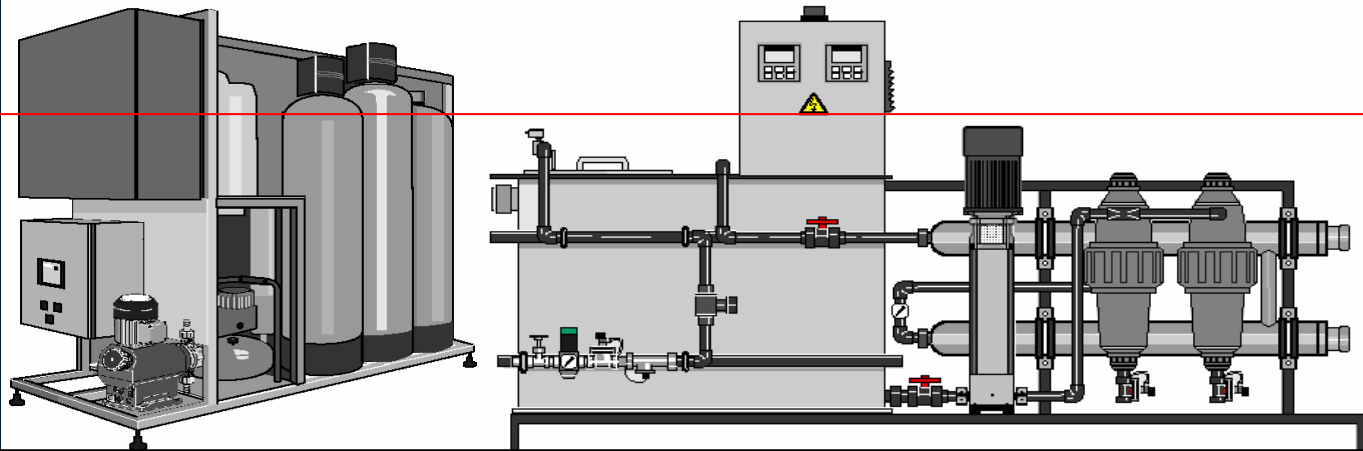

Legislation and environmental issues pertaining especially to pollution and salinity of water resources are leading to the introduction of restrictive measures regarding the disposal of plant growth solutions. New regulations are stimulating growers to switch from open to closed systems in which the nutrient solutions are circulated. This practice has risks since plant pathogens are easily spread in solutions, and growers have to tackle the problem by disinfecting the recycling water. Recycling water in closed irrigation techniques is the most effective approach that deals with the problem of water runoff in greenhouse production. Water circulation system is modular closed loop water recycling systems that is designed for greenhouse growers who use soilless culture. Hydroponics is the main market for ProFilter[®] systems. Proloop[®] systems covers all closed loop soilless systems and reduced the nutrient requirements in the feed water. The recycled water is used to irrigate and fertilize the crops as the Proloop[®] reduces the amount of water waste under current closed systems and reduces the amount of fertilizer used. All Proloop[®] systems are environmentally friendly easy to use and offers an efficient alternative solution to existing techniques applied in nursery irrigation. With the use of our customized dosing systems much closer amount of water and fertilizer added to the system avoiding unnecessary waste of water and harmful chemical build-up.

ProFilter® ProLoop® TFU range Water Recycling Systems Pathogen Prevention

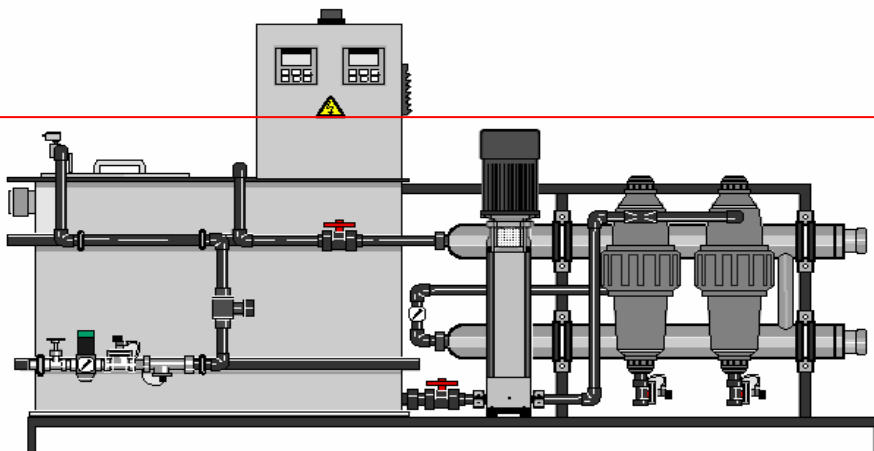

The ProLoop® TFU range was developed for water recycling used to irrigate, where compact, easy to use and modular design is desired. They stand out with their high level of automation and process control as well as for the short delivery and start-up times.

ProLoop® TFU systems use disc elements separation and ultraviolet purifiers utilize germicidal lamps with 254 nm especially designed for their use in the closed irrigation application techniques.

Germicidal lamps

UV lamps are installed in a quartz tube in the centre of a cylindrical, stainless steel or UV-C resistant plastic irradiation chamber. This quartz tube protects the UV lamp against the water and transmits approx. 85% of the UV-C radiation the water to be disinfected flows through the irradiation chamber.

A wiper mechanism provides the required cleaning of the quartz tube in which the UV lamps are installed. The radiation intensity is continuously measured by means of a UV-C sensor.

A special D.I.P process developed for disinfection in place cycle that can be automatically followed by a small injection of acid so no precipitations can be formed and the quartz tube is completely clean for the start of the next disinfection cycle.

Frequency-controlled pump

The ProLoop® TFU systems come supplied with a frequency controlled pressure pump as standard. This ensures that the plant operates always at its correct and optimum design point, independent of water consumption and fluctuating raw water supply pressures. This design also guarantees a lower energy consumption compared to conventional systems.

Disc elements

These elements are constructed from plastic discs that are stacked onto a telescopic core the discs are grooved on both sides.

These grooves intersect to form the filtration element when compressed on the core. The disc element provides high retention of organic matter.

The effective filtration area is comprised of both the outside surface and the channels formed by the intersected grooves. Suspended organic particulate adheres to the grooved surface adding the element of depth to the filtration process.

Cleaning the disc element is made simple by the unique design of the telescopic core which allows the discs to separate during the cleaning process.

- Low energy consumption
- No minimum flow requirement
- No reduction of pH level
- No temperature increase
- Low maintenance costs
- Compact design
- Scalable number of lamps, flexible extension
- Easily connected to new and existing installation
- Several capacity sizes and multiple UV-C chambers
- Alarms for lamp burning and life cycle, UV-C dose
- Computer controlled for automatic start/stop
- Inputs for tank level and water meter

ProFilter[®] ProLoop[®] TFU range Water Recycling Systems Pathogen Prevention

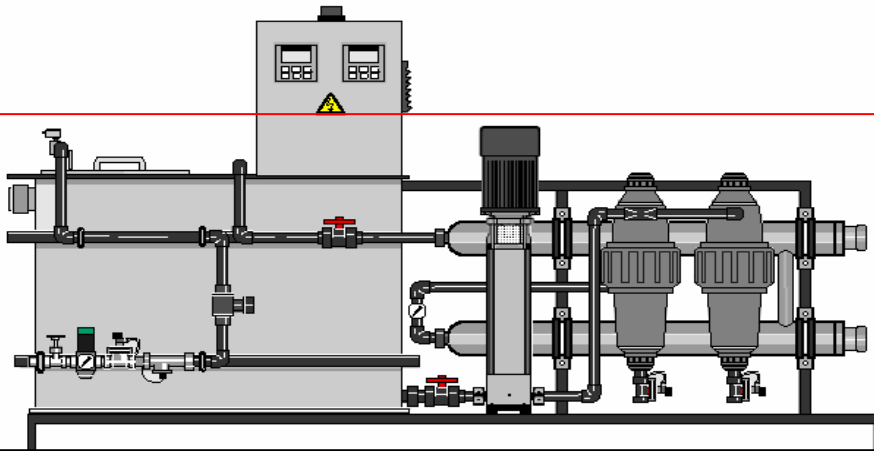

The systems are of a compact, modular design allowing for easy expansion if required. Our philosophy is to design, built and supply easy-to operate plants that can be operated by personnel at any level.

Removal of viruses and bacteria

The system effectively removes all traces of bacteria, viruses and other micro-organisms as well as their spores, where conventional disinfection mechanisms fail.

Stand type: For Recycling water in closed irrigation application produce water and circulate pathogen free irrigated water Operating on principle of disk filtration and UV-C radiation These units include all package and Components.

Unit design: stainless steel base frame with plastic front panel to house the instruments and controls

Pipe: According to DIN Pipe installation PVC,PP,PE

Special inlet filter: Polyamide/Glass fiber with two pressure gauges and one solenoid Flash valve

pump: Low noise, Multi stage Centrifugal stainless steel 316

modules: Polyethylene disc element 22 µm with high active surface area .

Valves and instruments: Including feed water sampling valve, solenoid inlet valve, feedwater pressure switch,flow meter, radiation monitor,pH meter, vibration resistant pressure gauges for pump and filters ,recirculation flow rate monitor.

Microprocessor control system: Fully automated monitoring and control of the filters and ultraviolet purifiers unit housed in FRP IP 54 control cabinet.

ProFilter® ProLoop® TFU range Water Recycling Systems Pathogen Prevention

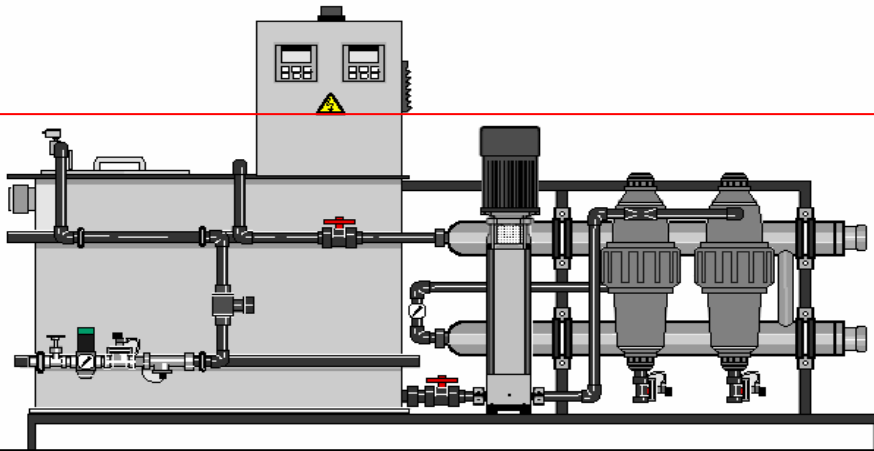

MODEL	Gallons per Minute	Gallons per Hour	Inlet and Outlet	Length mm	Width mm	Height mm
ProLoop® TFU1	4	264	1"	2000	540	1500
ProLoop® TFU2	8.6	516	1"	2000	540	1500
ProLoop® TFU3	13.2	792	2"	2000	540	1500
ProLoop® TFU5	83	4,980	2"	2000	540	1500
ProLoop® TFU10	166	9,960	2"	3000	540	1500
ProLoop® TFU15	250	15,000	2"	3000	540	1500
ProLoop® TFU20	333	19,980	2"	3000	540	1500
ProLoop® TFU25	416	24,960	2"	3000	540	1500

ProFilter® ProLoop® TAFU range Water Recycling Systems Pathogen Prevention

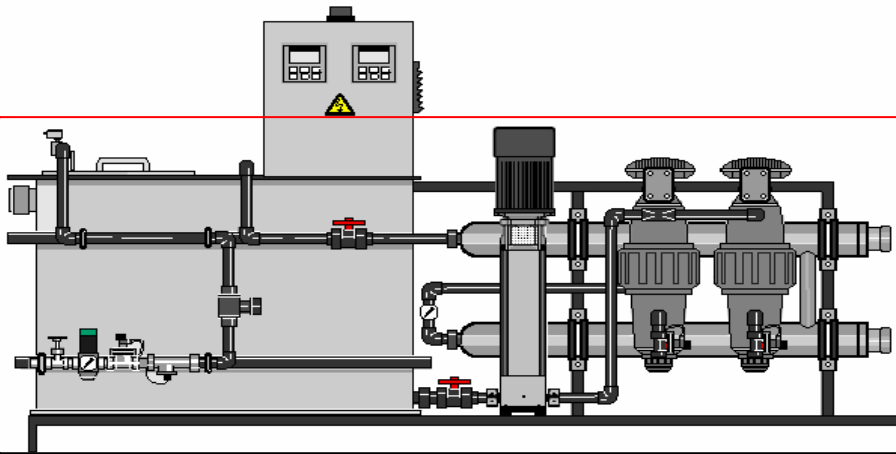

The ProLoop® TAFU range was developed for water recycling used to irrigate, where compact, easy to use and modular design is desired. They stand out with their high level of automation and process control as well as for the short delivery and start-up times.

ProLoop® TAFU systems use screen with Self-cleaning elements separation and ultraviolet purifiers utilize germicidal lamps with 254 nm especially designed for their use in the closed irrigation application techniques.

Germicidal lamps

UV lamps are installed in a quartz tube in the centre of a cylindrical, stainless steel or or UV-C resistant plastic irradiation chamber. This quartz tube protects the UV lamp against the water and transmits approx. 85% of the UV-C radiation the water to be disinfected flows through the irradiation chamber.

A wiper mechanism provides the required cleaning of the quartz tube in which the UV lamps are installed. The radiation intensity is continuously measured by means of a UV-C sensor.

A special D.I.P process developed for disinfection in place cycle that can be automatically followed by a small injection of acid so no precipitations can be formed and the quartz tube is completely clean for the start of the next disinfection cycle.

Frequency-controlled pump

The ProLoop® TAFU systems come supplied with a frequency controlled pressure pump as standard. This ensures that the plant operates always at its correct and optimum design point, independent of water consumption and fluctuating raw water supply pressures. This design also guarantees a lower energy consumption compared to conventional systems.

Tafu elements

The TAFU elements are constructed of molded plastic ribs that support a stainless steel weave-wire screen or monofil polyester weave screen with filtration degrees from 22 to 800 micron Suspended solids accumulate on the inside surface of the screen.

The direction of flow in these elements is from the inside out along the element. The screen elements are especially suitable for the separating of organic and inorganic particles and create a very low head loss.

The self-cleaning mechanism and the suction scanner nozzles sweeps across the entire screen surface in a spiral motion by a combined action of the hydraulic turbine and the piston.

The suction scanner nozzles vacuum the dirt from the screen surface and expel it out the exhaust valve.

- Low energy consumption
- No minimum flow requirement
- No reduction of pH level
- No temperature increase
- Low maintenance costs
- Compact design
- Scalable number of lamps, flexible extension
- Easily connected to new and existing installation
- Several capacity sizes and multiple UV-C chambers
- Alarms for lamp burning and life cycle, UV-C dose
- Computer controlled for automatic start/stop
- Inputs for tank level and water meter

ProFilter[®] ProLoop[®] TAFU range Water Recycling Systems Pathogen Prevention

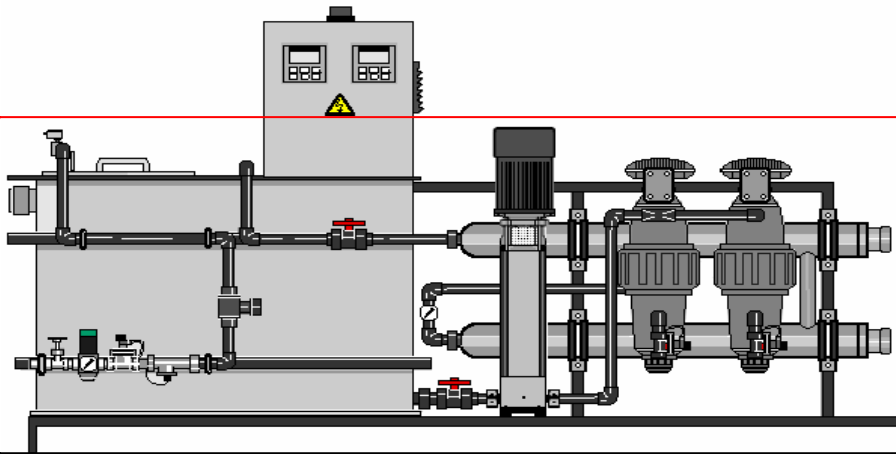

The systems are of a compact, modular design allowing for easy expansion if required. Our philosophy is to design, built and supply easy-to operate plants that can be operated by personnel at any level.

Removal of viruses and bacteria

The system effectively removes all traces of bacteria, viruses and other micro-organisms as well as their spores, where conventional disinfection mechanisms fail.

Stand type: For Recycling water in closed irrigation application produce water and circulate pathogen free irrigated water Operating on principle of screen filtration and UV-C radiation These units include all package and Components.

Unit design: stainless steel base frame with plastic front panel to house the instruments and controls

Pipe: According to DIN Pipe installation PVC,PP,PE

Special inlet filter: Polyamide/Glass fiber with two pressure gauges and suction scanner for self-cleaning mechanism.

pump: Low noise, Multi stage Centrifugal stainless steel 316

modules: stainless steel element with high active surface area .

Valves and instruments: Including feed water sampling valve, solenoid inlet valve, feedwater pressure switch,flow meter, radiation monitor,pH meter, vibration resistant pressure gauges for pump and filters ,recirculation flow rate monitor.

Microprocessor control system: Fully automated monitoring and control of the filters and ultraviolet purifiers unit housed in FRP IP 54 control cabinet.

ProFilter® ProLoop® TAFU range Water Recycling Systems Pathogen Prevention

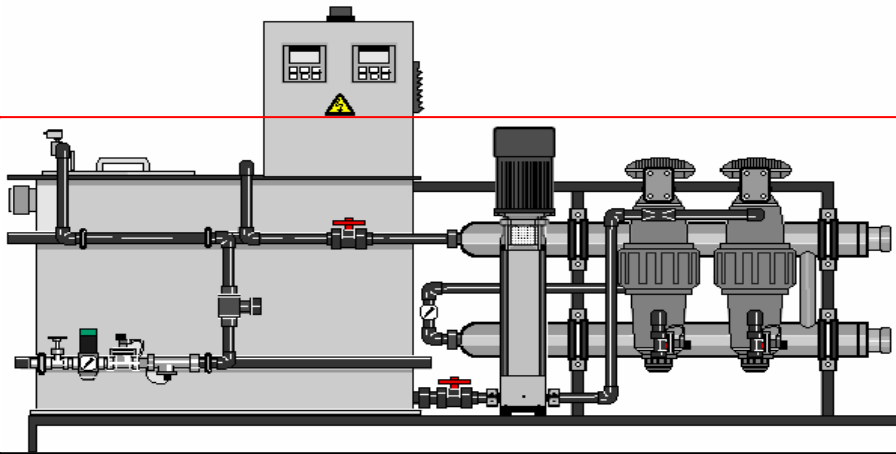

MODEL	Gallons per Minute	Gallons per Hour	Inlet and Outlet	Length mm	Width mm	Height mm
ProLoop® TAFU1	4	264	1"	2000	540	1500
ProLoop® TAFU2	8.6	516	1"	2000	540	1500
ProLoop® TAFU3	13.2	792	2"	2000	540	1500
ProLoop® TAFU5	83	4,980	2"	2000	540	1500
ProLoop® TAFU10	166	9,960	2"	3000	540	1500
ProLoop® TAFU15	250	15,000	2"	3000	540	1500
ProLoop® TAFU20	333	19,980	2"	3000	540	1500
ProLoop® TAFU25	416	24,960	2"	3000	540	1500

ProFilter® ProLoop® ELM range Water Recycling Systems Pathogen Prevention

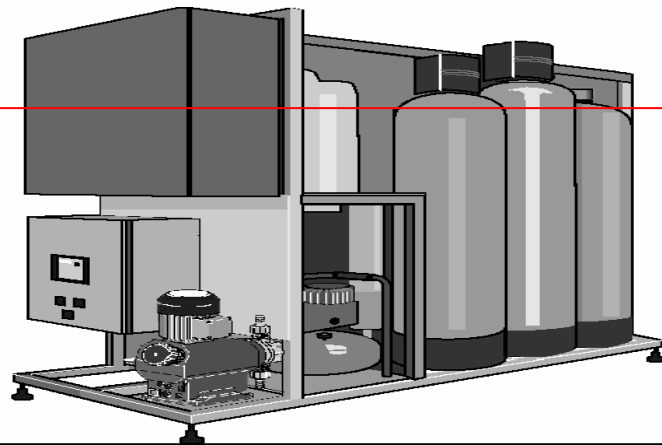

The ProLoop® ELM range was developed for water recycling used to irrigate, where compact, easy to use and modular design is desired. They stand out with their high level of automation and process control as well as for the short delivery and start-up times.

ProLoop® ELM systems use media filtration and unique electrolytic reactor that destroy all traces of bacteria, viruses and other micro-organisms as well as their spores. ProLoop® ELM designed for use in the closed irrigation application techniques.

Electrolytic reactor

The growth of slime, algae, fungus, and plant pathogens is prevented in water systems by circulating irrigation water through ELM systems. these innovated systems showed that root and plant diseases are prevented and the lifespan of cut flowers is prolonged. Growers who are using ELM technology in livestock applications have shown reduced mortality, improved health status and a higher conception rate.

A special D.I.P process developed for disinfection in place cycle that can be automatically followed by a small injection of oxidizing agent.

Sand filter

sand/anthracite filters will remove suspended solids from the water The water is passed through a bed of sand and anthracite to produce clear water with typically less than 1 ppm of solids.

The accumulated matter is removed by a high velocity backwash system coupled with an air scour when required. On multiple installations the filter units can be arranged to provide clean water for the backwashing operation without the need for a backwash water storage tank. Pressure filters manufactured from high quality coated steel or FRP.

Stand type: For Recycling water in closed/open irrigation application produce water and circulate pathogen free irrigated water operating on principle of filtration and electrolytic reactor .These units include all package and Components.

Unit design: stainless steel base frame with plastic panel to house the instruments and controls

Pipe: According to DIN Pipe installation PVC,PP,PE

inlet filter: sand/anthracite filters with two pressure gauges and automatic backwash valves for self-cleaning mechanism.

Dosing pump: Motor drive polypropylene or pvc head Low noise.

Electrolytic reactor : titanium electrode housed in conductance reactor.

Valves and instruments: Including feed water sampling valve, solenoid inlet valve, feed water pressure switch, flow meter, current monitor, vibration resistant pressure gauges for pump and filters, recirculation flow rate monitor.

Microprocessor control system: Fully automated monitoring and control of the filters and electrolytic unit housed in FRP IP 54 control cabinet.

ProFilter® ProLoop® ELM range Water Recycling Systems Pathogen Prevention

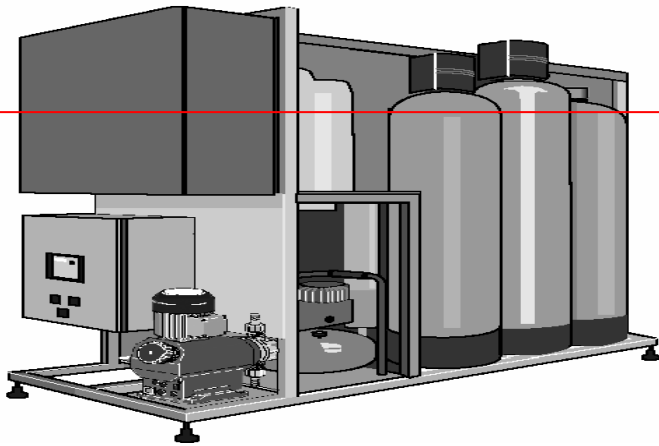

MODEL	Gallons per Minute	Gallons per Hour	Inlet and Outlet	Length mm	Width mm	Height mm
ProLoop® ELM 3	3.17	190.2	1	2000	1500	2000
ProLoop® ELM 4	4.28	256.8	1	2000	1500	2000
ProLoop® ELM 6	6.50	390	1	2000	1500	2000
ProLoop® ELM 8	8.73	523.8	1	2000	1500	2000
ProLoop® ELM 15	15.39	923.4	1.5	3000	1500	2000
ProLoop® ELM 19	19.84	1190.4	1.5	3000	1500	2000
ProLoop® ELM 30	30.79	1847.4	2	3000	1500	2000
ProLoop® ELM 41	41.74	2504.4	2	3000	1500	2000
ProLoop® ELM 59	59.52	3571.2	2	3000	1500	2000
ProLoop® ELM 74	74.60	4476	3	3000	1500	2000

ProFilter[®] ProLoop[®] MEM range Water Recycling Systems Pathogen Prevention

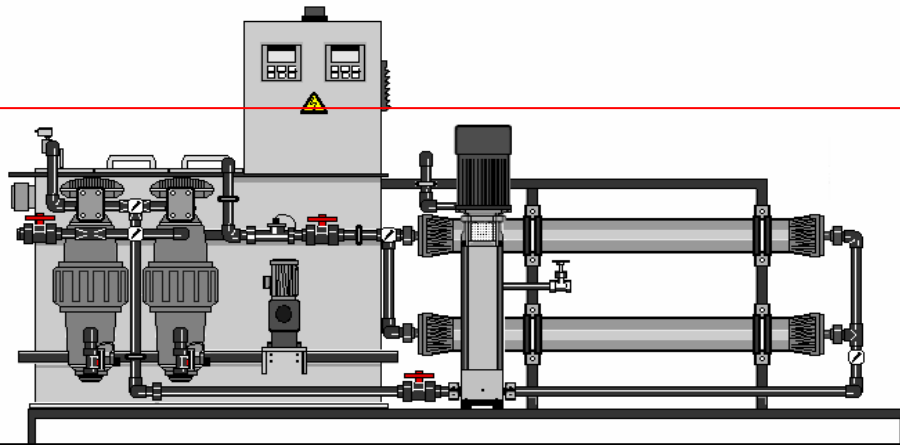

This stand type ProLoop[®] MEM units standard range represents the TreatMent[®] standard model for modern re-circulation requirements water treatment systems. These plants are specifically designed to produce water that meets today's stringent standards. The systems use uniquely designed filtration modules in a hollow fiber configuration to remove the following contaminants from re-circulation closed loop irrigation water systems.

- Suspended Solids/Turbidity
- Viruses
- Bacteria
- Cysts
- Arsenic
- Organics

ProLoop[®] MEM units are Equipped with the latest generation of hollow fiber membranes these plants achieve maximum filtration capacity at low operating cost and ensuring reduced investment. In addition these plants are available with integrated semi-automated cleaning system filtrate and feed water flushing option. Special customized versions are possible with the ProLoop[®] MEM units range. Different pipework materials and different Measurement/control equipment, e.g. conductivity, redox potential or pH measurement, and dosing equipment in pretreatment and post-treatment can easily be integrated in these plants.

The ProLoop[®] MEM stand type mounting 1-150 M³/h range was designed to filter and recycling of water in closed irrigation techniques.

Stand type: For produce of recycling of water in closed irrigation techniques. Operating on principle of Ultra filtration these units include the water pretreatment Components.

Unit design: Stainless steel base frame with frp front panel control box IP54 to house the instruments and controls

Pipe: According to DIN Pipe installation PVC

Special inlet filter: Polyamide/Glass fiber with two pressure gauges and suction scanner for self-cleaning mechanism.

pump: Low noise, Multi stage Centrifugal stainless steel 316

modules: hollow fiber membranes with high active surface area in GRP,PVC,SS316 pressure vessels Pore Size 0.03 µm.

Valves and instruments: Including feed water sampling valve, solenoid inlet valve, feedwater pressure switch, filtrate and concentrate flow meter, vibration-resistant pressure gauges for pump and concentrate pressure stainless steel valve for adjustment of filtrate, concentrate and concentrate recirculation flow rate.

Microprocessor control system: Fully automated monitoring and control of the Ultra filtration unit with MCC panel.

ProFilter[®] ProLoop[®] MEM range Water Recycling Systems Pathogen Prevention

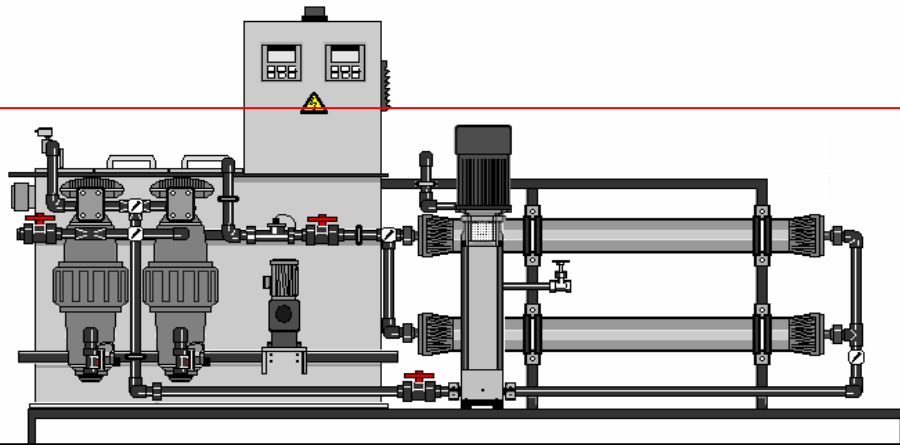

Optional features:

- Motor inverter
- Products water flow meter
- Waste water flow meter
- Waste recycle valve
- Oxidant Dosing Systems
- Process meter
- Plc control
- Integrated Cleaning system
- Filtrate or feed Turbidimeters
- Storage tank
- Uv sterilizer
- Disinfectant Dosing Systems
- Digital totalizing flow meters
- Air Compressor Systems
- Process meter
- Different pipework materials
- Modem for Remote Access
- Repressurization system

ProFilter[®] ProLoop[®] MEM range Water Recycling Systems Pathogen Prevention

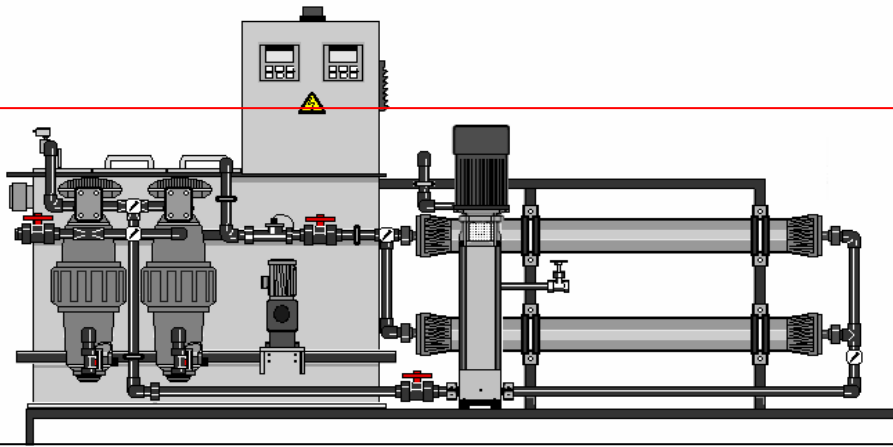

MODEL	Gallons per Minute	Gallons per Hour	Inlet and Outlet	Length mm	Width mm	Height mm
ProLoop [®] - MEM 1	4.0	238.1	1"	3000	1000	1500
ProLoop [®] - MEM 2	7.9	476.2	1"	3000	1000	1500
ProLoop [®] - MEM 3	11.9	714.3	2"	3000	1000	1500
ProLoop [®] - MEM 4	15.9	952.4	2"	3000	1000	1500
ProLoop [®] - MEM 5	19.8	1190.5	2"	3000	1000	1500
ProLoop [®] - MEM 5	23.8	1428.6	2"	3000	1000	1500
ProLoop [®] - MEM 6	27.8	1666.7	2"	3000	1000	1500
ProLoop [®] - MEM 7	31.7	1904.8	2"	3000	1000	1500
ProLoop [®] - MEM 8	35.7	2142.9	2"	3000	1000	1500
ProLoop [®] - MEM 9	39.7	2381.0	2"	3000	1000	1500
ProLoop [®] - MEM 10	43.7	2619.0	2"	3000	1000	1500
ProLoop [®] - MEM 11	47.6	2857.1	2"	3000	1000	1500
ProLoop [®] - MEM 13	55.6	3333.3	2"	3000	1000	1500
ProLoop [®] - MEM 14	59.5	3571.4	2"	3000	1000	1500
ProLoop [®] - MEM 14	63.5	3809.5	2"	3000	1000	1500
ProLoop [®] - MEM 15	67.5	4047.6	2"	3000	1000	1500
ProLoop [®] - MEM 16	71.4	4285.7	2"	3000	1000	1500
ProLoop [®] - MEM 17	75.4	4523.8	2"	3000	1000	1500
ProLoop [®] - MEM 18	79.4	4761.9	2"	3000	1000	1500
ProLoop [®] - MEM 19	83.3	5000.0	2"	3000	1000	1500
ProLoop [®] - MEM 20	87.3	5238.1	2"	3000	1000	1500
ProLoop [®] - MEM 21	91.3	5476.2	2"	3000	1000	1500

ProFlow[®] Transfer Pumps packaged systems

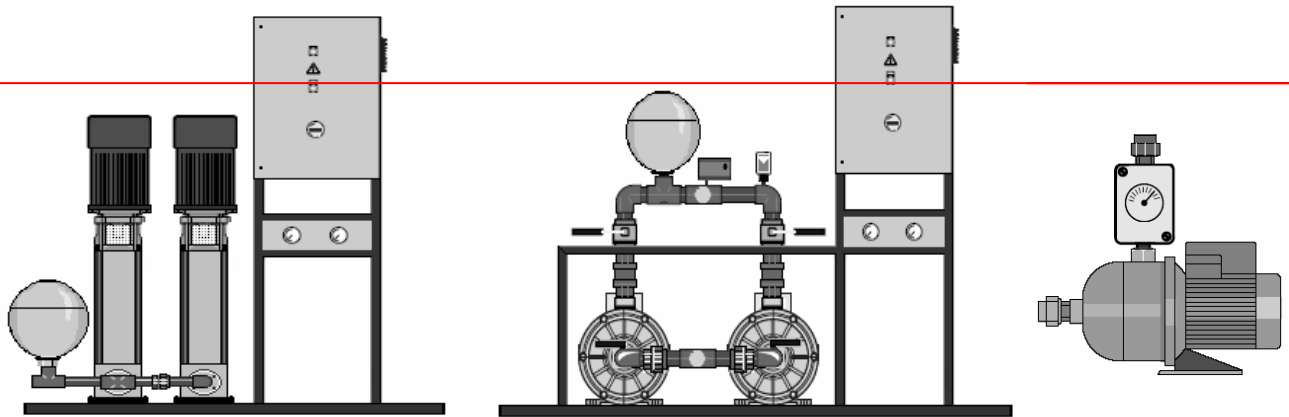

The ProFlow[®] pump station is a pre-engineered and fabricated line of packaged booster systems that provide maximum hydraulic capabilities of 1500 GPM and up to 340 PSI. The ProFlow[®] provides pressure boosting for a variety of applications including:

- high – rise buildings
- industrial plants,
- agriculture / irrigation
- municipal and rural water districts.

The use of ProFlow[®] variable frequency drive technology and our patented pump control logic, has created an intelligent pump system which virtually eliminates the requirement for most mechanical protection devices.

Utilizing the ProFlow[®] variable speed controller on each pump allows for the maximum energy efficiency, as well as back-up protection should a pump fault during operation. Even with your changing system demands, the ProFlow[®] pumping station provides consistent performance, while still providing a compact and economical package!

- All systems are UL rated.
- Maximum footprint, on most sizes, allow systems to fit through standard doorways.
- 200 – 230 Volt single phase up to 20 HP,
- 200 – 230 Volt three phase up to 75 HP,
- 460 Volt up to 75 HP.
- Each system is fabricated with stainless steel or cast iron centrifugal pumps with a variety of electrical and mechanical options to choose from.
- Standard "off the shelf" motors
- Significant reduction in energy consumption over fixed speed systems.
- System protection from overvoltage, undervoltage, blocked suction, cavitation, NPSHa, phase loss, short circuit, transducer failure and motor current overload
- Liquid temperatures up to 212÷ F.
- Ambient temperatures up to 104÷ F.
- Maximum operating pressures up to 360 psi.
- Pump run-out protection.
- Dry running protection.
- Programmable lead/ lag alternation.
- Programmable system curve/ friction loss compensation.
- Programmable system pressure starting.
- Fault detection and alarms relay.
- Motor run relay.
- Programmable soft start.
- Stainless steel, pp, pvc manifolds.
- Isolation valves.
- Optional suction / low pressure switch.
- Optional pressure relief valves and temperature relief valves.
- Optional lightning protection.
- Optional flexible discharge hose.

ProFlow[®] Transfer Pumps packaged systems

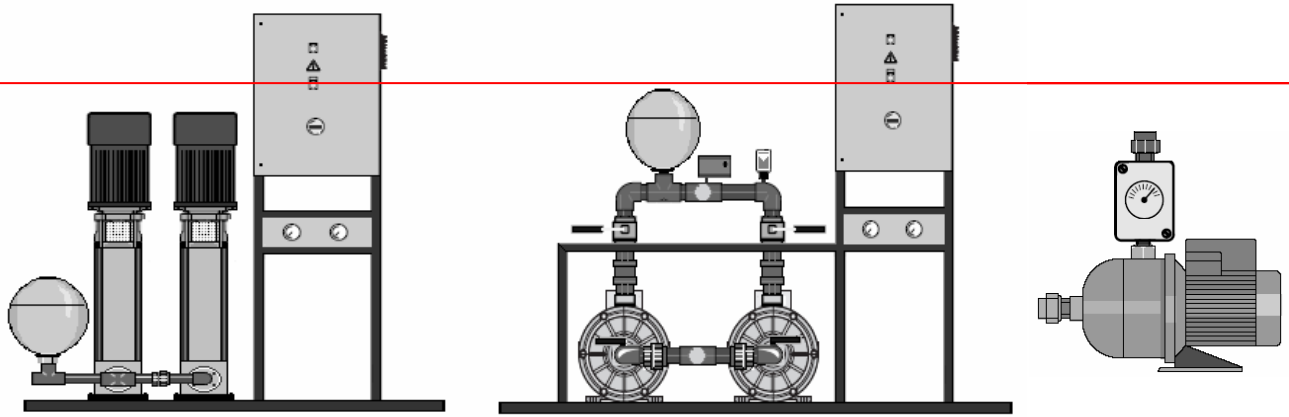

MODEL	Pressure high meter	Q M3/H	KW	HP
ProFlow [®] -2HM4DPJET	14÷31	1÷4.2	0.5	0.6
ProFlow [®] -2HM5DPJET	18÷42	1÷4.2	0.55	0.75
ProFlow [®] -2HM7DPJET	23÷59	1÷4.2	0.75	1
ProFlow [®] -4HM5DPJET	8÷30	2.4÷7.8	0.55	0.75
ProFlow [®] -4HM7DPJET	10÷40	2.4÷7.8	0.75	1
ProFlow [®] -4HM9DPJET	12÷50	2.4÷7.8	0.90	1.2

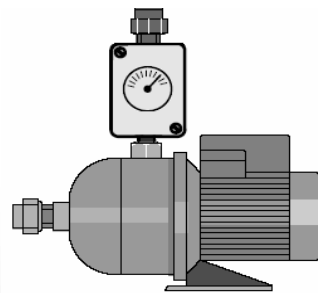

MODEL	KW	HP	Q M3/H	0	3.6	4.8	6	7.2	9.6	12	14.4
ProFlow [®] 4HM4IVJET	0.55	0.75	Meter H pressure	36	31.5	29.5	28	26	22	17	11
ProFlow [®] 4HM9IVJET	0.90	1.2		60	52	51.2	48.6	46	39.5	32.5	23.6
ProFlow [®] SV40IVJET	1.1	1.5		70	62	59.5	56	53	46	37	26

ProFlow® Transfer Pumps packaged systems

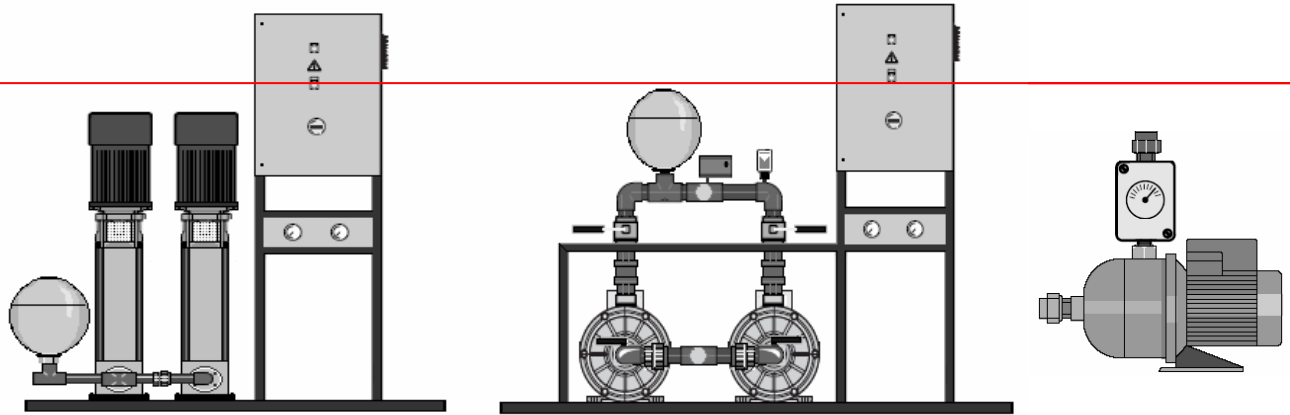

MODEL	Pressure high meter	Q M3/H	KW	HP
ProFlow®-2HM4DPJET	14÷31	1÷4.2	0.5	0.6
ProFlow®-2HM5DPJET	18÷42	1÷4.2	0.55	0.75
ProFlow®-2HM7DPJET	23÷59	1÷4.2	0.75	1
ProFlow®-4HM5DPJET	8÷30	2.4÷7.8	0.55	0.75
ProFlow®-4HM7DPJET	10÷40	2.4÷7.8	0.75	1
ProFlow®-4HM9DPJET	12÷50	2.4÷7.8	0.90	1.2

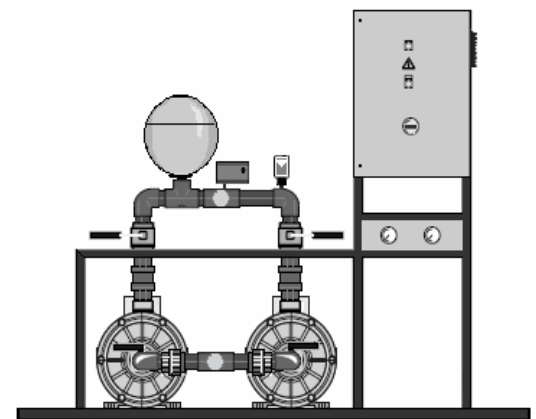

MODEL	KW	HP	Q M3/H	0	3.6	4.8	6	7.2	9.6	12	14.4
ProFlow® 4HM4IVJET	0.55	0.75	Meter H pressure	36	31.5	29.5	28	26	22	17	11
ProFlow® 4HM9IVJET	0.90	1.2		60	52	51.2	48.6	46	39.5	32.5	23.6
ProFlow® SV40IVJET	1.1	1.5		70	62	59.5	56	53	46	37	26

ProKit[®] Water quality check

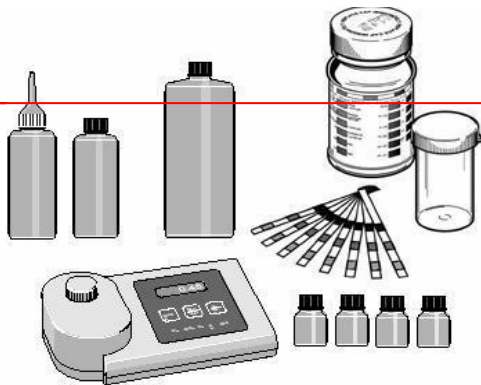

TREATMENT[®] leads the way in technology for the domestic, industrial and commercial water and soil management markets as well. We supply a wide range of photometer and comparator instruments, test kits and reagent systems for the detection of many elements.

Whatever your applications, TREATMENT[®] instruments offer the most reliable methods available in portable meters using the latest technology.

TREATMENT[®] supply a core product range of pre-packaged analytical tests for water analysis based on methods approved and accepted worldwide. There are a range of technologies suitable for different applications:

- Comparator methods for basic field tests
- Photometer methods for accurate monitoring of critical systems
- Tubetests - liquid reagents for effluent analysis
- Tablet/Drop count kits for industrial applications
- New Chemical Sensor Technology for heavy metals and new techniques

Effluent & Wastewater Testing

COD•Ammonia•Nitrate•Total Nitrogen•Phosphate, Total Phosphorous•Nickel•Chromium•Iron•Zinc
Copper• Dissolved Oxygen

Water Testing

Alkalinity•Aluminium•Ammonia•Boron•Bromine• Calcium Hardness•Chloride•Chlorine Chlorine Dioxide•Chromium•COD Chemical Oxygen Demand•Colour•Copper•Cyanuric Acid Dissolved Oxygen•Fluoride•Hardness•Hydrazine•Hydrogen Peroxide•Iron•Magnesium•Manganese•Molybdate Nickel•Nitrate•Nitrite•Organophosphonate•Ozone pH•Phenol PHMB• Phosphate•Potassium•Silica Sulphate•Sulphide•Sulphite•Turbidity•Zinc

Drop Count

Alkalinity M•Alkalinity P•Calcium Hardness Chloride•Total Hardness•Organophosphonate Nitrite•Sulphite•Tannin• phosphate• pH• Conductivity